

the hallicrafters co.

MANUFACTURERS OF ELECTRONIC EQUIPMENT, CHICAGO 24, U. S. A.

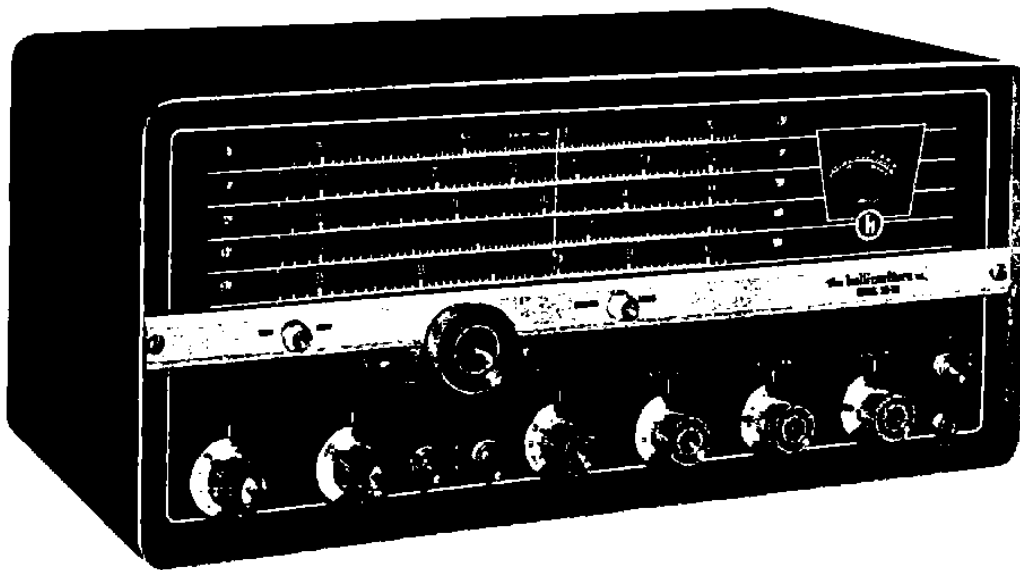

O92-104359B

Figure 1. Hallicrafters Model SX-111 Selectable Sideband Receiver

SECTION I GENERAL

Your new Hallicrafters SX-111 Selectable Sideband Receiver is precision built to bring you the finest in radio reception. This fourteen tube, including voltage regulator and rectifier, dual conversion superheterodyne receiver tunes the 80, 40, 20, 15 and 10 meter bands, plus several of the MARS frequencies and 10MC from WWV on a large 9-1/2 inch slide-rule type dial. The receiver provides for the reception of CW, AM, and single-sideband (SSB) signals on all bands, the upper or lower sideband being readily selectable by means of a front panel control. Separate detectors are used for the reception of AM and SSB/CW signals. Selection of the detector to be used is accomplished through the BFO switch mounted on the front panel.

Unlike the ordinary dual-conversion receiver, your SX-111 receiver employs dual conversion on all bands. "Razor-sharp" selectivity is made possible by the use of an adjustable 50.75 KC second IF with four high-Q, permeability-tuned circuits. Receiver selectivity is variable in five steps from 500 cycles to 5 KC at 6 DB down and from 5 to 20 KC at 60 DB down.

A tuned RF stage assures maximum sensitivity and a high signal-to-noise ratio for outstanding reception of weak and distant signals. A manual RF GAIN control prevents overloading by strong signals. An antenna trimmer, adjustable from the front panel, permits peaking of the RF stage to compensate for loading effects of various antennas. A notch filter circuit allows rejection of an extremely narrow portion of the IF passband. With the notch filter, an interfering signal can easily be "notched out". The position of notch rejection is adjustable from the front panel.

Outstanding frequency stability is achieved by the use of concentric air trimmers and ceramic coil forms

in the 1st conversion oscillator, extensive temperature compensation, voltage regulation of all oscillators, and the use of a crystal-controlled 2nd conversion oscillator.

Tuning is accomplished by a precision drive tuning mechanism to insure extremely close calibration and accurate resetability. Smooth flywheel tuning affords maximum traverse speed and operating ease. The tunable portion of the receiver is designed to spread each band over most of the dial for easy and accurate tuning. Dial graduations are provided for 10 KC on the 80, 20, and 15 meter bands. On 40 meters there is a dial graduation for every 5 KC; on 10 meters, there is a dial graduation for every 25 KC.

An automatic series noise limiter circuit, controlled by a switch on the front panel, effectively reduces interference from electrical equipment, ignition noise, and other forms of pulse type noise.

An "S" meter is used when receiving AM signals to indicate the accuracy of tuning and the relative strength of received signals. The meter is calibrated in "S" units from 1 to 9, and in decibels above S9 to +60 DB. The "S" meter is operative when AVC is turned ON and the RF GAIN control is set at or near maximum (extreme clockwise position).

The "STANDBY" position of the FUNCTION switch on the front panel silences the receiver but leaves the heater and plate power on to provide instant reception between transmission periods. Provision has also been made in the receiver for remote receive-standby control.

Audio output connections include terminals for a 3.2 ohm speaker and a 500/600 ohm output for line or speaker. A front panel jack for headphones is also provided.

a 100 KC calibration oscillator. This is accomplished by tuning in the 10 MC WWV signal and comparing it with the calibration oscillator signal.

Band 6 on the receiver is used to check and adjust

SECTION II TECHNICAL SPECIFICATIONS

RECEPTION AM, CW and SSB
INTERMEDIATE FREQUENCY (Double Conversion);
FREQUENCY COVERAGE 50.75 KC and 1650 KC

SPEAKER OUTPUT 3.2 and 500 ohm (See para. 3-5). Rear chassis mounted 3 contact screw type terminal strip.

BAND	CALIBRATED RANGE
80 Meters	3.5 - 4.0 MC
40 Meters	7.0 - 7.3 MC
20 Meters	14.0 - 14.4 MC
15 Meters	21.0 - 21.5 MC
10 Meters	28.0 - 29.7 MC
WWV 10 MC	

HEADPHONE OUTPUT 50 to 2,000 ohm (See para. 3-6). Panel mounted phone jack accepts standard 1/4" phone plug.

ANTENNA INPUT 50-70 ohm (See para. 3-3). Rear chassis mounted 2 contact screw type terminal strip and a rear chassis mounted socket accepts an RCA type phone plug for coaxial inputs.

SENSITIVITY Less than 1 microvolt for a 10 DB signal to noise ratio.

SELECTIVITY Five position switch providing .5, 1, 2, 3, and 5 KC selectivity at 6 DB down.

MUTE STRIP Rear chassis mounted 2 contact screw type terminal strip for remote cut-off of receiver.

POWER SOURCE 105-125 volts, 50/60 cycles AC.

DIMENSIONS 18-11/16" wide, 8-13/16" high, 10-3/16" deep.

POWER CONSUMPTION 83 watts.

NET WEIGHT Approximately 35-3/4 lbs.

NUMBER OF TUBES 14 including voltage regulator and rectifier.

SHIPPING WEIGHT Approximately 40-lbs.

SECTION III INSTALLATION

3-1. UNPACKING

After unpacking the receiver, examine it closely for damage which may have occurred in transit. Should any sign of damage be apparent, file a claim immediately with the carrier stating the extent of damage. Carefully check all shipping labels and tags for instructions before removing or destroying them.

tion from either a single wire antenna, or a half-wave doublet or other tuned antenna. Optimum matching will be effective however, when using transmission line having an impedance in the range of 50 to 70 ohms. Antenna connections are made to a two-terminal strip at the rear of the receiver marked "A", and "G". A connector for coaxial cable installations is also provided.

3-2. LOCATION

The receiver may be placed in any location that will permit free air circulation through the ventilation holes and openings in the cabinet. Avoid excessively warm locations such as those near radiators and heating vents. The external speaker may be located in any convenient position although it is recommended that it not be placed on top of the receiver.

3-3-1. SINGLE WIRE ANTENNA

The simplest antenna, and one which will provide satisfactory results throughout all bands, is a conventional single-wire antenna. (See Figure 2.) Simply attach one end of this wire to terminal "A", and then run the wire about the room in any convenient manner. If the receiver is operated in a steel constructed building or where receiving conditions are exceptionally poor, an outside antenna, 50 to 100 feet long may be necessary. The outside antenna should be erected as high as possible and kept free from surrounding objects. In some locations, reception may be im-

3-3. ANTENNAS

The RF input of the receiver is designed for opera-

proved by connecting a ground wire (ordinary copper wire) from terminal "G" to a cold water pipe. While the use of an outside ground rod, installed in accordance with Insurance Underwriter's Laboratories requirements, is adequate protection against lightning, we strongly recommend an additional connection to the nearest cold water pipe to eliminate any shock hazard.

3-3-2. HALF-WAVE DOUBLET ANTENNA

For top performance on a particular band, the use of a half-wave doublet or other type of antenna employing a 50 to 70 ohm transmission line is recommended. A typical doublet antenna installation is shown in Figure 3. The overall length in feet of a doublet antenna is determined by the following formula:

$$\text{Length in feet} = \frac{468}{\text{Frequency in megacycles}}$$

The doublet antenna is directional and should be erected with its entire length facing a desired station for maximum signal pickup.

The doublet antenna may be fed with either a balanced or unbalanced transmission line. When a balanced line such as "twin-lead" or a twisted pair is used, the line connects to terminals "A" and "G". When using an unbalanced line such as coaxial cable, the inner conductor connects to terminal "A" and the outer metal braid connects to terminal "G", or the coaxial connector supplied with the receiver may be used. A ground wire may improve reception when using an unbalanced type line.

The doublet antenna provides optimum performance only for the band for which it is cut. Therefore, when using such a doublet antenna, it may be desirable for reception on other bands to utilize the antenna as a single wire type. This is accomplished by connecting the two transmission line leads together and connecting them to terminal "A".

In an installation where the receiver is used in conjunction with a transmitter, it may be advantageous to use the same antenna for receiving as for transmitting.

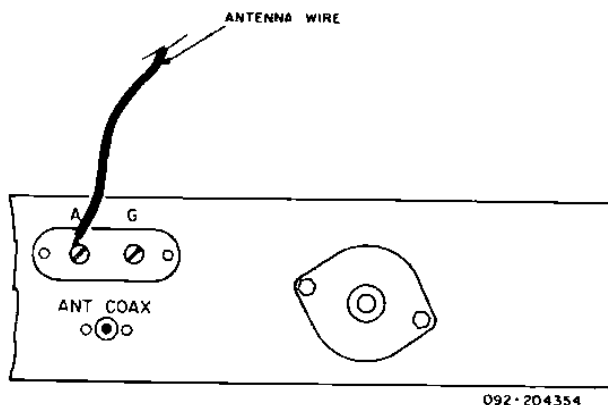

Figure 2. Single Wire Antenna

This is especially true when a directive antenna is used since the directive effects and power gain of the transmitting antenna are the same for receiving as for transmitting. Switching of the antenna from the transmitter to the receiver may be accomplished with an antenna changeover relay or knife switch connected in the antenna leads.

For further information regarding receiving antennas and antenna matching schemes, refer to the "Radio Amateur's Handbook" or the "A. R. R. L. Antenna Book", both published by the American Radio Relay League, West Hartford, Conn., U. S. A.

3-4. POWER SOURCE

The receiver is designed to operate on 105 to 125 volt, 50/60 cycle AC current. Power consumption is 83 watts.

IMPORTANT: If in doubt about your power source, contact your local power company prior to inserting the power cord into an AC power outlet. Plugging the power cord into the wrong power source can cause extensive damage to the unit, requiring costly repairs.

3-5. SPEAKER

A three-terminal strip, marked "G", "3.2" and "500", is provided at the rear of the receiver for connecting the external speaker that is required with the receiver. (See Figure 4.) Any permanent magnet speaker with a 3.2 ohm voice coil can be used by simply connecting the two leads from the speaker voice coil to the terminals marked "3.2" and "G". If it is desired to use a speaker with a voice coil impedance other than 3.2 ohms, a matching transformer should be employed to insure optimum performance. The transformer should be mounted on or near the speaker, and should have a 5 watt power rating, a 500 ohm primary impedance, and a secondary impedance to match the impedance of the speaker voice coil. Connect the primary of the transformer to the terminals marked "500" and "G" and the secondary to the speaker voice coil terminals.

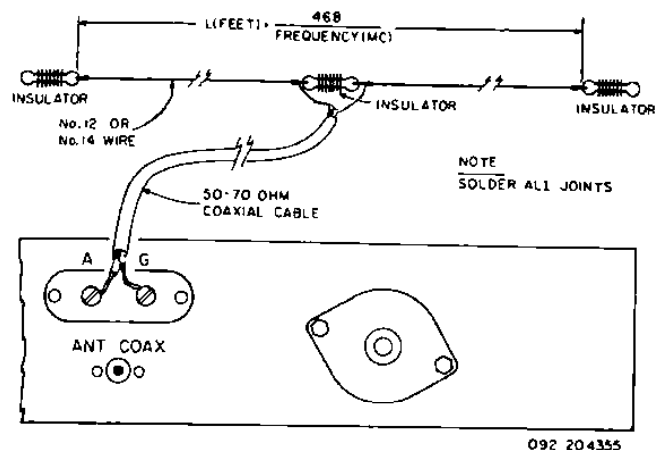

Figure 3. Doublet Antenna Using Twin-Lead Transmission Line

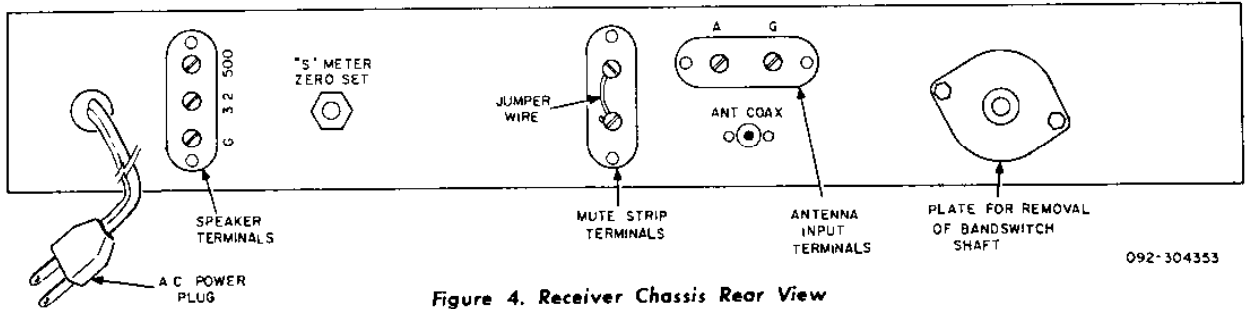

Figure 4. Receiver Chassis Rear View

The Hallicrafters R-46B, R-47 and R-48 speakers are designed for use with your receiver. Those speakers should be connected to the terminals marked "3.2" and "G".

3-6. HEADPHONES

The headphone jack, marked "PHONES" is located on the front panel of the receiver and is so wired that the 3.2 ohm speaker terminal is automatically silenced when the headphones are inserted. The headphone impedance is not critical, and any commercial headphones ranging from 50 ohms to 2000 ohms will provide satisfactory performance. The 500 ohm speaker tap is connected at all times.

3-7. REMOTE RECEIVE-STANDBY SWITCH

The receiver may be disabled from a remote lo-

cation by connecting a remote SPST switch between the terminals of the mute strip (TS2) located at the rear of the receiver. (See Figures 4 and 5.) The jumper wire is removed from the mute strip and connecting leads are run to the remote switch or relay. The receiver is muted when the remote switch or relay is open. The receiver will function when the remote switch or relay contacts are closed. If the receiver is to be operated with a remote switch, the FUNCTION switch on the front panel cannot be left at "STANDBY".

CAUTION

When remote switching is not intended, the wire jumper must be connected between the two terminals of the mute strip.

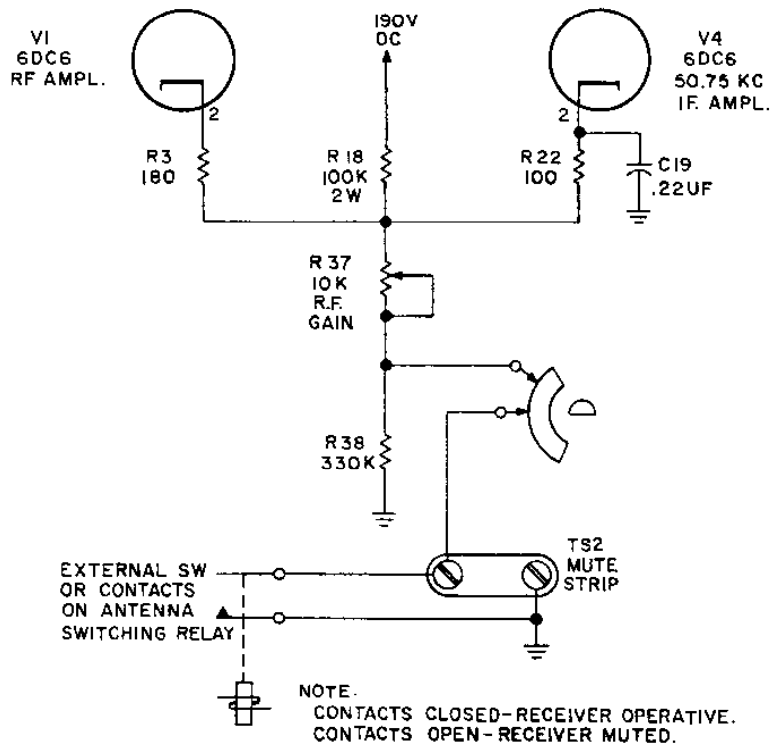

Figure 5. Schematic Diagram of Remote Receive-Standby Circuitry

SECTION IV

FUNCTION OF OPERATING CONTROLS

4-1. RF GAIN CONTROL

The RF GAIN control varies the gain of the RF amplifier and the 6DC6 50.75 KC IF amplifier stage. Maximum sensitivity is obtained with the control set at "10" (fully clockwise). In this position, the tubes being controlled are operated at maximum gain with minimum cathode bias. As the control is rotated counterclockwise, the bias on the tubes increases with a resultant decrease in gain.

4-2. BAND SELECTOR CONTROL

The BAND SELECTOR control operates the band switch to place the proper set of coils and capacitors into the circuit to cover the desired band. The band covered by each position of the BAND SELECTOR control is indicated directly on the control. The first five positions are the 80, 40, 20, 15 and 10 meter bands, respectively. The sixth position tunes in the 10 MC WWV signal, and is indicated on the 10 meter scale with a special marking. This band is available for calibrating the 100 KC crystal calibrator.

4-3. ANTENNA TRIMMER CONTROL

The ANT. TRIMMER control operates a variable capacitor connected across the secondary of the antenna coil of the band in use. This capacitor adjustment compensates for loading effects of various types of antenna installations. The control is adjusted for maximum signal after the tuning control is adjusted to the desired frequency. Once adjusted, the ANT. TRIMMER control usually requires very little adjustment until the BAND SELECTOR control is operated to select another band.

4-4. AUDIO GAIN CONTROL

The AUDIO GAIN control adjusts the audio level at the speaker terminals and "PHONES" jack. Clockwise rotation of the control increases the signal applied to the grid of the audio amplifier tube, thus increasing receiver volume; counterclockwise rotation decreases volume. In some cases when receiving CW or SSB signals, it may be advantageous to advance the AUDIO GAIN control one-half to three-quarters clockwise, and control receiver volume with the RF GAIN control.

4-5. AVC SWITCH

The AVC switch, when set at "ON", places the AVC circuit in operation to maintain the output level of the receiver constant regardless of normal input-signal variations. AVC voltage is applied to the RF amplifier stage, the 1st Mixer, and the 1650 KC IF amplifier stage.

4-6. NOISE LIMITER SWITCH

This switch, when set at "ON", places the automatic series noise limiter circuit in operation to reduce pulse type noises such as ignition noise and electrical interference. The limiter is most effective on AM recep-

tion, which allows the signal to pass through the receiver unaffected, but makes the receiver inoperative for noise amplitudes greater than those of the signal.

The noise limiter circuit "chops" noise peaks received at the detector by means of a biased diode which becomes non-conducting above a predetermined signal level. When the limiter circuit is in operation, the audio output of the detector must pass through the limiter diode to the grid of the audio amplifier. The limiter diode normally acts as a conductor for the audio signal as long as the diode plate is positive with respect to its cathode. When a noise peak is higher in amplitude than the signal, it instantaneously swings the cathode positive with respect to the plate, conduction ceases, and that portion of the signal is automatically cut off from the audio amplifier. The point at which the limiter diode becomes non-conducting is made sufficiently high so that the diode will not clip modulation peaks and thus impair intelligibility, but yet low enough to limit the noise peaks effectively.

This type of efficient noise limiter circuit greatly reduces "listening fatigue" which can accompany long periods of reception.

4-7. BFO SWITCH

This switch, when set at "ON", applies plate voltage to the beat frequency oscillator (BFO) and the product detector to render the stages operative for the reception of CW or single-sideband signals. The beat frequency oscillator employs a Hartley oscillator circuit and is voltage regulated to insure highly stable operation. The "OFF" position of the switch disables the BFO and product detector for normal reception of AM phone signals.

4-8. SELECTIVITY CONTROL

The SELECTIVITY control is used to vary the selectivity of the receiver to fit receiving conditions. Five degrees of selectivity are available, ranging from 500 cycles for CW reception under crowded band conditions, to 5 KC for maximum fidelity when band conditions permit. (See Figure 7.) The five selectivity positions are indicated on the SELECTIVITY control and indicate receiver selectivity at 6 DB down.

As mentioned above, and when conditions permit, the SELECTIVITY control is normally set at 5 KC, the position affording broadest selectivity. Selectivity may be progressively increased and passband decreased by turning the control to the positions marked "3 KC", "2 KC", "1 KC", and ".5 KC. For reception of the crowded bands, it is generally advisable to sacrifice some fidelity for greater selectivity, since the added selectivity reduces both adjacent-channel interference and background noise by attenuating the higher audio frequencies. Too much selectivity on AM signals, however, will attenuate the high audio frequencies to such an extent that the signal may become unintelligible as a result of excessive sideband cutting. When receiving CW signals, the sharpest selectivity position may be used without the loss of intelligibility experienced in AM reception.

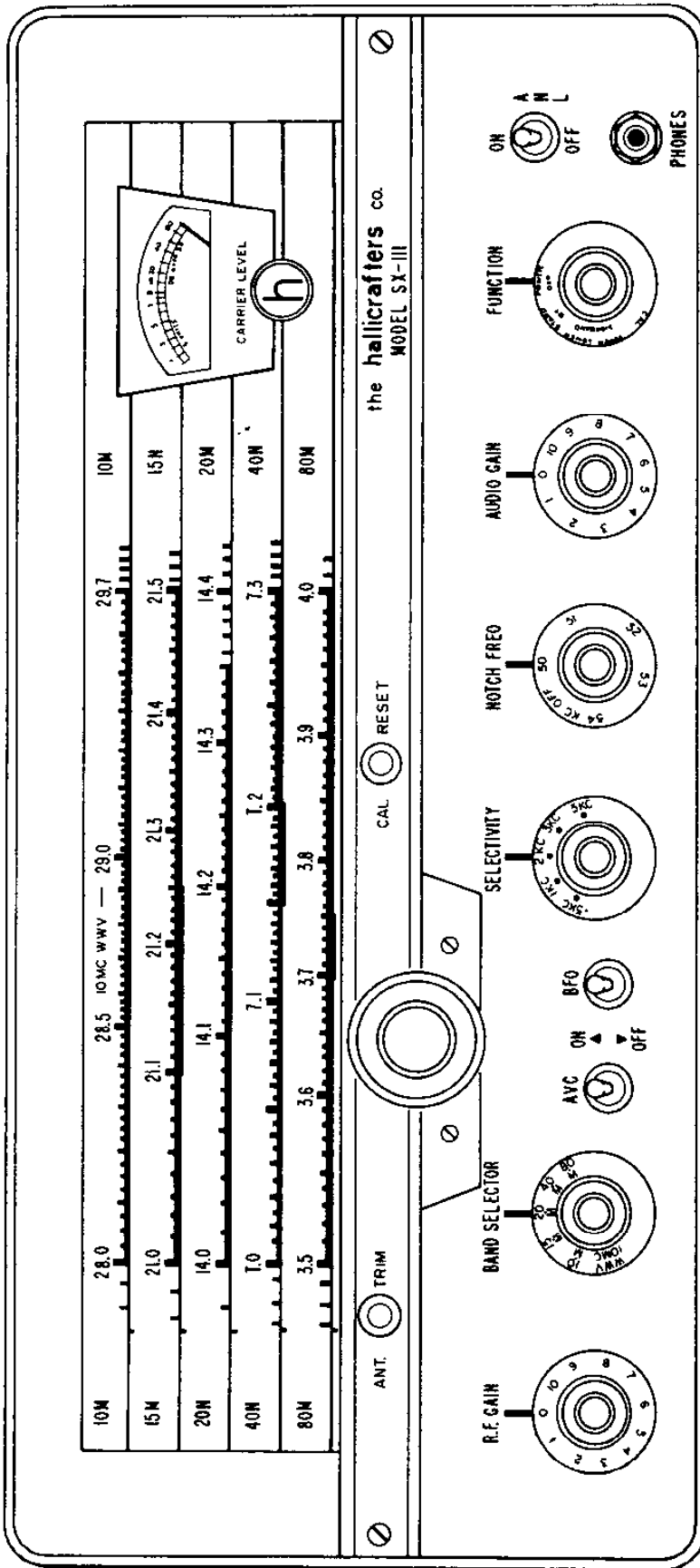

092-007352

Figure 6. Operating Controls

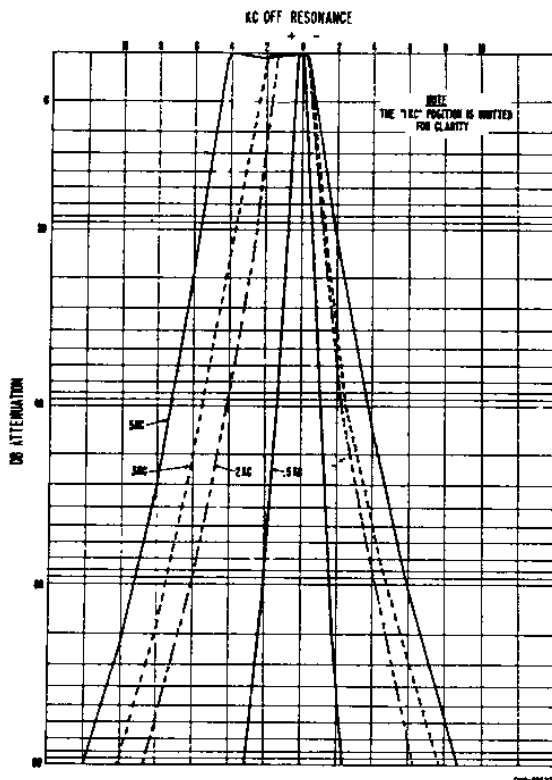

Figure 7. IF Selectivity Curves

4-9. "T" NOTCH FILTER

The notch filter circuit provides a means of eliminating or reducing the interfering effect of certain types of heterodynes or CW signals. To obtain maximum results from this feature of your receiver, the use of the control associated with the notch filter circuit is fully explained below.

GENERAL

The manner in which the notch filter will affect the IF selectivity of the receiver is illustrated in Figure 8. The filter will suppress an extremely narrow band of frequencies within the IF bandpass range of the receiver. The effectiveness of this notch is many times greater than the notch of a quartz crystal filter at 400 KC to 2 MC. The NOTCH FREQ. control will move the band of suppressed frequencies, represented by the notch in the selectivity curve, to any point within the IF pass band.

Extensive field testing of this feature has shown that the notch filter is highly effective in suppressing the type of interference for which this type of circuit is intended. It must be appreciated, however, that any selective IF filter circuit, including the phasing notch of quartz crystal circuits, affects only a limited range of interference frequencies. The effectiveness of the notch filter is therefore somewhat dependent upon the exact nature of the interfering signal. For example: a heterodyne within the IF range that is less than 900 cycles in width and has little harmonic content is readily notched out. If the same interfering heterodyne is rich in harmonics, it would only be possible to completely

suppress the fundamental frequency, and the remaining harmonic content may remain almost equally objectionable. It logically follows that if two interfering heterodynes should appear within the IF passband that are separated in frequency by more than 500 to 900 cycles, it would be possible to notch out only one of the heterodynes. The interfering signal may also vary in frequency beyond the range of the notch filter, and thus reduce the effectiveness of the circuit. Under these conditions, increasing selectivity will generally eliminate its heterodyne. It has been found, however, that the notch filter is sufficiently effective in many instances to make an otherwise useless signal entirely readable.

4-10. NOTCH FREQUENCY CONTROL

To activate the Notch Filter circuit advance the NOTCH FREQUENCY control from the "OFF" position.

"NOTCH FREQ." CONTROL - This control tunes the notch in the IF passband and may be set anywhere in the range of from 50 KC to 54 KC. When not in use, set the control at the "OFF" position. The approximate frequency is calibrated on the knob skirt. While tuning this control for maximum suppression of the interfering heterodyne with minimum distortion to the desired signal, try to visualize the notch moving across the selectivity curve, Figure 8. It is then readily apparent that improper tuning may notch out the desired signal instead of the heterodyne. It may be necessary to move the notch across the desired signal in order to reach the heterodyne that you desire to suppress. The important consideration is to tune the NOTCH FREQUENCY control for maximum heterodyne suppression with minimum distortion to the desired signal.

4-11. FUNCTION CONTROL

The FUNCTION control performs four functions: (1) it turns the receiver on and off; (2) "STANDBY" disables the receiver, keeping the heaters and B+ on; (3) it switches the 2nd conversion oscillator to operate at the required frequency for reception of CW, AM, and single-sideband signals (1600 KC in the "LOWER SIDE-BAND" position and 1700 KC in the "UPPER SIDE-BAND"); and (4) "CALIBRATE" activates the 100 KC crystal calibrator.

In the "POWER OFF" position, the receiver is completely inoperative. As the control is turned clockwise to any of the other three functions, the receiver power is turned on.

The "LOWER SIDE-BAND" and "UPPER SIDE-BAND" positions of the control are used when receiving single-sideband signals or when it is desired to receive one or the other sideband of an AM signal.

To illustrate how selectable sideband reception is accomplished in the receiver, a numerical example is given. Consider an incoming signal at 7000 KC, modulated 1 KC. Since modulation of a carrier causes the generation of sideband frequencies numerically equal to the carrier frequency plus or minus the modulation frequency, the incoming signal consists of the carrier at 7000 KC, a lower sideband at 6999 KC, and an upper sideband at 7001 KC. (See Figure 9A.)

The incoming signal is first heterodyned with the output of the 1st conversion oscillator in the 1st mixer stage. The 1st conversion oscillator operates at a frequency higher than the incoming signal by an amount equal to the first-intermediate frequency of 1650 KC. As a result of the frequency conversion process, three new lower frequencies are produced in the output of the 1st mixer: the carrier at 1650 KC; the lower sideband at 1651 KC, and the upper sideband at 1649 KC. (See Figure 9B.) These signals are amplified by the 1650 KC IF amplifier stage and then heterodyned with the output of the 2nd conversion oscillator in the 2nd mixer stage. The 2nd conversion oscillator is crystal controlled and can be set to operate at either 1600 KC for reception of the lower sideband, or 1700 KC for the reception of the upper sideband, selection being made by means of the FUNCTION control. When the FUNCTION control is set at "LOWER SIDEBAND", the 1600 KC signal from the 2nd conversion oscillator is heterodyned with the incoming signal at the first-intermediate frequency of 1650 KC to produce three new frequencies: the carrier at 50 KC, the lower sideband at 51 KC, and the upper sideband at 49 KC. By referring to Figure 9C, it can be seen that the lower sideband falls within the IF pass-band and the upper sideband falls outside of the pass-band. Thus the lower sideband is accepted and the upper sideband is rejected. When the FUNCTION control is set at "UPPER SIDEBAND", the 1700 KC signal from the 2nd conversion oscillator is heterodyned with the incoming signal. In the frequency conversion process, the carrier still remains at 50 KC, but now the upper sideband appears at 51 KC, and the lower sideband appears at 49 KC. (See Figure 9D.) Thus, the sideband is accepted and the lower sideband is rejected

Under conditions of crowded bands, the sideband which is most affected by other interfering signals can be rejected, thereby greatly eliminating much of the interference or "QRM". When receiving an AM signal, it is possible to change sidebands during the course of reception, in order to offset changing "QRM" conditions due to adjacent signals disappearing and reappearing within the band.

The CAL. position controls the operation of the

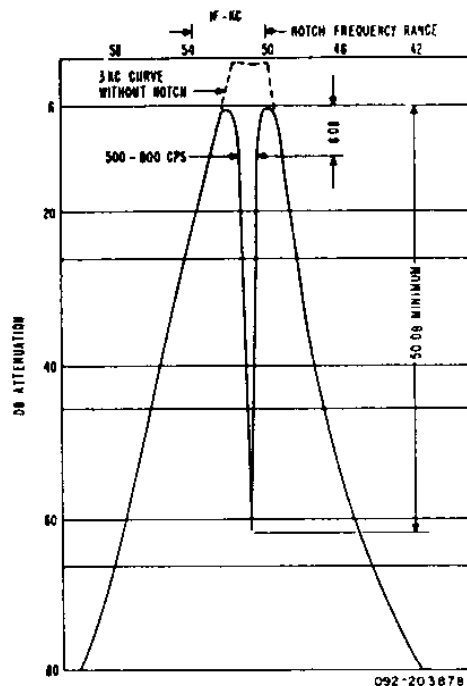

Figure 8. IF Selectivity Curve With Notch

100 KC crystal calibrator. When the switch is set at "CAL.", the crystal calibrator is turned on to provide marker signals at every 100 KC point on the receiver. The crystal calibrator employs a crystal controlled pentode oscillator circuit. The output of the crystal calibrator is capacitively coupled to the antenna input circuit. A trimmer capacitor, adjustable by the CRYSTAL ADJ control on the top of the calibrator unit, permits adjustment of the calibrating crystal to exactly 100 KC by comparison with the 10 MC signal (band 6, WWV 10 MC) transmitted by WWV. This capacitor has been set at the factory and should normally not require periodic readjustment unless extreme calibration accuracy is required. If adjustment is required, proceed as outlined in para. 5-8.

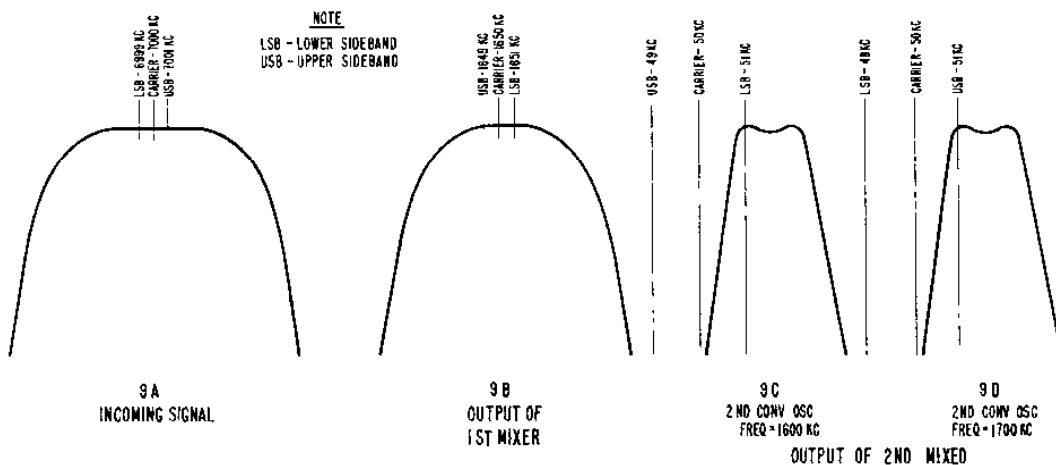

Figure 9. Selectable-Sideband Response Curves

092-402584-C

The FUNCTION control, when set at "STANDBY", permits disabling of the receiver during transmission periods, at the same time maintaining the heater and plate supplies operative for instant use when reception is again resumed. The receiver operates normally when the switch is at LSB, USB and CAL. positions.

4-12. TUNING CONTROL

The TUNING control is used to tune the desired signals within the selected band. The vertical pointer on the slide-rule dial is operated by this control. The

dial has five calibrated and illuminated scales. A sixth band, which uses the dial area covering the 10 meter band scale, is purposeful for zero-beating the 10 MC WWV signal for intentions of checking and adjusting the 100 KC crystal calibrator.

It should be noted that the large slide-rule dial spreads the bands over most of the total length of the calibrated dial. When checked against the 100 KC crystal calibrator, and dial correction made with the CAL. RESET control, the dial calibration between adjacent 100 KC points is extremely accurate.

SECTION V OPERATION

5-1. AM RECEPTION

1. Set the front panel controls to their starting positions as outlined below.

RF GAIN 10 (maximum sensitivity)
 BAND SELECTOR At the desired band
 AUDIO GAIN 0 (minimum volume)
 AVC ON-OFF ON
 NOISE LIMITER OFF
 BFO OFF
 SELECTIVITY 5 KC
 FUNCTION POWER OFF
 CAL. RESET As adjusted
 ANT. TRIMMER As adjusted
 NOTCH FREQ. 54 KC OFF

2. Turn the receiver on by rotating the FUNCTION control clockwise and set it at the LSB position. The tuning dial and "S" meter will light up indicating the receiver is operative. Rotate the AUDIO GAIN control clockwise for the desired volume level.
3. Tune in an AM signal with the TUNING control, tuning for maximum indication on the "S" meter. Adjust the ANT. TRIMMER control for maximum indication on the "S" meter. After the signal has been accurately tuned in, readjust the AUDIO GAIN control as desired.

NOTE

The "S" meter indications will be correct only when the AVC switch is set at "ON", and the RF GAIN control is set to provide equal gain from band to band. See para. 5-5.

4. Set the SELECTIVITY control for the desired degree of selectivity. For AM reception, the control can be set to "5 KC" for maximum fidelity. The positions marked 3 KC, 2 KC, 1 KC, and .5 KC provide progressively increasing steps of selectivity. Note that as the selectivity of the receiver is increased, the background noise and interference from adjacent signals is reduced. Too much selectivity, however, may cause excessive sideband cutting. While sideband cutting reduces fidelity, it may be fre-

quently preferable to sacrifice naturalness of reproduction in favor of communications effectiveness. When changing the position of the SELECTIVITY control from a broad to a more narrow response (for example: from "2 KC" to "1 KC"), a slight readjustment of the tuning controls may be necessary to recenter the signal in the IF passband.

5. Set the FUNCTION control at either "LOWER" or "UPPER" SIDEBAND position.
6. If it is desired to operate with AVC off, set the AUDIO GAIN control to a well advanced position, and vary the receiver volume level by means of the RF GAIN control, taking care not to advance the control to a point where strong signals will cause "blocking".
7. If severe electrical disturbances, ignition or other types of pulse type noise interfere with reception, set the NOISE LIMITER switch at "ON" to place the automatic noise limiter circuit in operation.
8. The receiver may be disabled without turning it off by setting the FUNCTION switch at "STANDBY". In this position, the RF and 50.75 KC IF stages are cut off, but the heater and plate supplies remain operative for instant reception. To resume reception, simply return the switch to "LSB" or "USB" position.
9. An undesired signal near the frequency of the desired signal will heterodyne with it to produce an audible beat note equal to their frequency difference. This type of heterodyne interference can be eliminated by using the notch filter circuit. Simply adjust the NOTCH FREQ. control to "notch out" the interfering signal.

CAUTION

It is possible to eliminate the heterodyne by notching out the desired carrier in place of the undesired signal or carrier. When this occurs an AM signal will sound like single sideband suppressed carrier transmission (monkey chatter).

10. In shortwave reception, it frequently happens that transmission conditions are different for waves of slightly different frequencies. As a result, in the case of voice-modulated transmissions, AM particularly, which involve sideband frequencies differing slightly from the carrier frequency, the carrier and sideband components may not be received in the same relative amplitudes and phases they had at the transmitter. This effect, known as selective fading, causes severe distortion of the signal.

This type of distortion can be reduced considerably by utilizing the selectable sideband feature of the SX-111 receiver operating in an "exalted mode", i. e., the transmitted carrier is positioned out of the receiver's IF passband along with one sideband producing a suppressed carrier single sideband signal. The carrier is subsequently reinserted by the receiver's product detector and the signal is detected in the same manner as in the case of a SSB signal. The detailed procedure for this type of operation is as follows:

- a. Set the BFO switch at "ON", and the FUNCTION control at either the "LOWER" or "UPPER" SIDEBAND position.
- b. Carefully tune in the desired signal for a "zero beat".
- c. If the receiver BFO is set up properly (See paragraph 5-6), the FUNCTION switch may be alternately set to either the "UPPER" or "LOWER" SIDEBAND positions without affecting the "zero beat" condition.
- d. Leave the FUNCTION switch in the "UPPER" or "LOWER" SIDEBAND position that affords the best reception.

5-2. CW RECEPTION

For CW reception, the receiver may be operated with AVC on or off, as desired. Operation of the receiver with AVC on is highly desirable since it not only minimizes fading but also prevents blasting when tuning from a weak to a strong signal. To operate with AVC on, set the AVC switch at "ON", set the RF GAIN control to a well advanced position, and regulate the receiver volume level by means of the AUDIO GAIN control. To operate with AVC off, set the AVC switch at "OFF", set the AUDIO GAIN control at a well advanced position, and vary the receiver volume level by means of the RF GAIN control, taking care not to advance the control to a point where strong signals cause excessive "thumping" (overloading).

CW signals are made audible by the heterodyning action of the BFO with the incoming signal. The BFO is set at a frequency slightly different from the second-intermediate frequency of 50.75 KC, the difference being equal to the pitch of the audible note desired.

For the reception of CW signals, set the BFO switch at "ON", set the SELECTIVITY control at one of the sharper selectivity positions (2 KC, 1 KC, or .5 KC, set the FUNCTION control at the "UPPER" SIDEBAND position, and then tune in the signal for a pleasing beat

note.

NOTE

When the SELECTIVITY control setting changes from a broad to a more narrow position it may be necessary to retune the receiver slightly to properly position the signal in the more narrow passband. Changing from a sharp to a more broad position, however, will not require re-tuning.

The setting of the SELECTIVITY control for CW reception is generally best determined by receiving conditions. Note that as the selectivity of the receiver is increased (SELECTIVITY control varies from the ".5 KC" to the "2.5 KC" position), the background noise and adjacent-channel interference is considerably reduced and tuning is sharper. For CW reception, the sharpest selectivity position may be used without the loss of intelligibility experienced in AM reception.

5-3. SINGLE SIDEBAND RECEPTION

Single-sideband signals are transmitted with little or no carrier, and it is necessary to reinsert the carrier in the receiver before proper reception is obtained. In the SX-111 receiver, this is accomplished in the 50.75 KC IF system by injecting the BFO signal at the input of the product detector. Until properly tuned in a single-sideband signal (SSB) can be identified by its non-intelligibility and by severe variations in the "S" meter indication corresponding to the speech modulation.

For the reception of single-sideband signals, set the AVC switch at "ON", BFO switch at "ON", and SELECTIVITY control at either "2 KC" or "3 KC", depending upon adjacent channel interference and noise. Set the RF GAIN control at a well advanced clockwise position and vary the receiver volume level by means of the AUDIO GAIN control, taking care not to advance the RF GAIN control to a point where strong signals will cause distortion (overloading). Set the FUNCTION control at either the "LOWER" or "UPPER" SIDEBAND position. The single-sideband signal will be intelligible in only one of these two positions, the proper position depending upon the sideband being transmitted. If the signal is not intelligible after tuning is completed as outlined below, set the FUNCTION control to the other sideband setting and repeat the tuning procedure.

After the controls have been properly set as outlined in the preceding paragraph, very carefully tune in the single-sideband signal for maximum intelligibility. It will be noticed that with incorrect tuning of a single-sideband signal, the speech will sound high or low pitched or very distorted but no trouble should be encountered in tuning once a little experience has been gained.

The "1 KC" position of the SELECTIVITY control permits reception of modulation frequencies up to about 1000 cycles. For reception of modulating frequencies higher than 1000 cycles, set the SELECTIVITY control to the positions marked "2 KC", "3 KC", or "5 KC", depending on the degree of fidelity desired; maximum fidelity is obtained in the "5 KC" position. Unlike CW on AM reception, it is not necessary to retune the receiver slightly when receiver selectivity is varied. The notch filter is especially useful during reception

of single-sideband signals. An undesired AM or CW signal close in frequency to the desired signal will heterodyne with the BFO to produce an audible beat. The undesired signal may be "notched out" with the notch filter, just as in AM or CW reception.

5-4. USE OF CRYSTAL CALIBRATOR

The 100 KC crystal calibrator permits accurate checking of dial calibration on every band by a comparison of the dial calibrations with the marker signals which appear at every multiple of 100 KC on the dial.

NOTE

It may be necessary to reduce the RF GAIN when it is desired to calibrate the 80, 40 and 20 meter bands. The crystal calibrator is directly coupled to the antenna terminal and is capable of overloading the receiver.

1. Set the TUNING dial at a convenient multiple of 100 KC at the low frequency end of the band in use (or nearest any particular frequency within the band it is desired to tune). Examples of low frequency end check are: 3500 KC on 80 meters, 7000 KC on 40 meters, 14,000 KC on 20 meters, 21,000 KC on 15 meters, and 28,000 KC on 10 meters.
2. Set the BFO switch at "ON", and the FUNCTION switch at "CAL."
3. Carefully adjust the TUNING control for the exact 100 KC frequency mark as indicated on the dial. If a "zero beat" does not occur when the vertical pointer falls on this 100 KC mark, adjust the CAL. RESET control until a "zero beat" can be obtained. For example, on the 80 meter band, a "zero beat" should be obtained at 3500, 3600, 3700, 3800, 3900, and 4000 KC.
4. The procedure outlined in steps 1 through 3 above provides average calibration accuracy over the entire frequency range of the band in use. For precise calibration accuracy over a particular section of the band, the procedure is identical except that the dial is set at a multiple of 100 KC nearest the desired frequency or range of frequencies, instead of at the low end of the band as in step 1.

5-5. USE OF "S" METER

The "S" meter provides a visual means of determining whether or not the receiver is properly tuned, as well as an indication of the relative signal strength. The "S" meter circuit consists of a DC milliammeter connected in the B+ feed circuit of the IF tube (V3), the grid of which is controlled by AVC voltage. Since the current of this tube varies with the strength of the incoming signal, the meter will indicate relative signal strength. The "S" meter is calibrated in "S" units from 1 to 9, and in decibels above S-9 to +60 DB. The indications on the "S" meter will be correct only when

the RF GAIN control is set to provide equal gain from band to band. For operation on the 10, 15, and 20 meter bands, the RF GAIN control should be set at "10"; for operation on the 80 and 40 meter bands, settings of 7 and 8 respectively will permit reasonably accurate indications on the "S" meter.

NOTE

The "S" meter will not indicate relative signal strength when the AVC switch is at OFF.

The limitations of the "S" scale should be fully understood before any assumption as to the indicated signal voltages is accepted. The meter indicates approximate signal strength as developed at the antenna input terminals when terminated in a 50-70 ohm load, at 14.3 MC. This approximation will have a variation on a new receiver and, obviously, as the tubes age the variations may be greater. The indicated readings at other frequencies will vary slightly from that at 14.3 MC, as previously explained. Also, all readings "S9" or less will be more accurate and correlate more closely than those with higher readings.

5-6. BFO FREQUENCY CHECK

The beat frequency oscillator (BFO) has been carefully adjusted at the factory so that its frequency is 50,0 KC. Readjustment of the BFO will normally not be required unless the 12AX7 BFO tube (1'2 of V9) or components in the BFO circuit have been replaced. A slight readjustment sometimes may be necessary occasionally as a result of normal aging of the BFO tube. If adjustment is necessary, it can be determined by the following procedure:

With the BFO switch at "ON", SELECTIVITY control at "5 KC", FUNCTION control at "UPPER" SIDEBAND, very carefully tune in an AM signal for a "zero beat". (See Note A below.) Leaving the receiver tuning unchanged, switch the FUNCTION control to the "LOWER" SIDEBAND position. If the beat oscillator frequency is correct, a "zero beat" will be obtained in both the "UPPER" and "LOWER" SIDEBAND positions. If, however, the beat oscillator is slightly off frequency, a beat note will be heard when switching from the "UPPER" SIDEBAND to the "LOWER" SIDEBAND position. Adjust the beat frequency oscillator until zero beat is obtained in both the "LSB" and "USB" positions without retuning the receiver. (See Figure 10 for the BFO frequency adjustment core location.)

NOTE A

In instances where the BFO is considerably off frequency, it may not be possible to obtain a "zero beat" when tuning in the signal. In this case, it will be necessary to first "roughly" set the BFO to operate at approximately 50.75 KC as follows: With the BFO switch at "ON", SELECTIVITY control at "5 KC", and FUNCTION control at "UPPER" SIDEBAND, tune the receiver to a noisy part of the band (not to a signal). Adjust the BFO (L20)

slug for minimum noise on the noise signals. Then set the SELECTIVITY control at "5 KC" and make the BFO frequency check as outlined in the preceding paragraph.

If the BFO frequency check indicates adjustment is necessary, proceed as follows:

Turn the BFO slug a few degrees to the left or right so as to lower the beat note frequency, and repeat the BFO frequency check. If the beat note obtained is higher in frequency than that obtained originally, it is an indication that the slug is being turned in the wrong direction. Continue varying the setting of the slug in small steps and repeating the BFO frequency check until "zero beat" is obtained in both the "UPPER" and "LOWER" SIDEBAND positions.

5-7. NOTCH FREQUENCY CHECK

Readjustment of the notch filter circuit is not normally necessary unless the components in the notch filter circuit are replaced. To check the circuit, proceed as follows:

Check the BFO frequency as instructed in Section 5-6. Set AVC to "ON" and the SELECTIVITY control at "3 KC". Tune in an unmodulated carrier, from a station (a transmitter VFO, or a signal generator) for a "zero beat". Place the BFO switch in the "OFF" position to de-energize the BFO. Tune the NOTCH FREQ. for a minimum reading on the "S" meter. The NOTCH FREQ. dial should be set at "50 KC".

If the notch frequency check indicates that an adjustment is necessary, proceed as follows:

Loosen the NOTCH FREQ. knob and reset it to indicate "50 KC". Rotate the control to approximately "51 KC". Tune across an unmodulated carrier while observing the "S" meter. (Use an approximate S-9 signal.) The meter will indicate two peaks. Readjust the NOTCH FREQ. control as necessary to approximately equalize the peaks. Then tune the receiver for a minimum reading on the "S" meter between the two peaks. Adjust the NOTCH DEPTH control R20, located on top of the SX-111 receiver chassis, for a minimum reading on the "S" meter. Refer to Figure 10 for the location of R20.

5-8. CRYSTAL CALIBRATOR CHECK

The CRYSTAL ADJ. control on the crystal calibrator chassis operates a trimmer capacitor con-

nected across the 100 KC calibrating crystal. This trimmer capacitor permits slight adjustment of the calibrating crystal to exactly 100 KC by comparison with the 10 MC signal transmitted by station WWV. This is done by setting the BAND SELECTOR to "WWV 10 MC" and tuning the receiver to the WWV 10 MC mark on the top scale of the slide rule dial. This capacitor has been set at the factory and should not require periodic readjustment unless extreme calibration accuracy is desired. If adjustment is required, proceed as outlined below.

Set the FUNCTION switch to "UPPER" SIDEBAND, and all other front panel controls as for normal AM reception. Tune in the 10 MC WWV signal and wait for the period during which the signal from WWV is unmodulated. Then switch on the crystal calibrator by setting the FUNCTION switch at CAL. and adjust its frequency, by means of the CRYSTAL ADJ. control until the crystal calibrator signal "zero beats" with the signal received from WWV. If the adjustment is attempted during periods that WWV is modulated, an erroneous zero beat may be obtained with the modulating frequency instead of the desired carrier frequency.

5-9. SERVICE OR OPERATION QUESTIONS

For any further information regarding operation or servicing of your SX-111 receiver, contact your Hallicrafters dealer. The Hallicrafters Company maintains an extensive system of Authorized Service Centers where any required service will be performed promptly and efficiently at a nominal charge. All Hallicrafters Authorized Service Centers display the sign shown below.



For the location of the one nearest you, consult your local dealer or telephone directory. Make no service shipments to the factory as The Hallicrafters Company will not accept the responsibility for unauthorized shipments.

The Hallicrafters Company reserves the privilege of making revisions in current production of equipment and assumes no obligation to incorporate these revisions in earlier models.

SECTION VI ALIGNMENT

6-1. GENERAL

This receiver has been carefully aligned at the factory by specially trained and experienced personnel using precision equipment. Alignment of the receiver should not be attempted until all other possible causes of faulty

operation have been investigated. Alignment should not be required unless the receiver has been tampered with or component parts have been replaced in the RF or IF stages. Alignment should be made only by persons familiar with communications receivers and experienced in their alignment. Refer to Figures 10 and 11 for location of all alignment adjustments.

6-2. EQUIPMENT REQUIRED

1. Signal generator covering 50 KC to 30 MC.
2. Vacuum tube voltmeter (VTVM) or other high impedance DC voltmeter.
3. Output meter (or AC scale of VTVM). Connect output meter to appropriate speaker output terminals. If a VTVM is used, connect it to terminals "500" and "G" and terminate the output with a 500 ohm resistive dummy load.

6-3. INITIAL CONTROL SETTINGS

BAND SELECTOR. As indicated in chart
 RF AND AUDIO GAIN. 10 (maximum)
 AVC AND NOISE LIMITER. OFF
 BFO. OFF
 SELECTIVITY. As indicated in chart
 FUNCTION. LOWER SIDEBAND
 TUNING. Gang half meshed
 ANT. TRIMMER. Mid point
 CAL. RESET. Mid point
 NOTCH FREQ. 54 KC OFF or as indicated in chart

CAUTION NOTICE: ALL OSCILLATOR TRIMMER CAPACITORS ARE SOLDERED AFTER ADJUSTMENT, AND ANY READJUSTMENT REQUIRES THE REMOVAL OF THIS "FIXING" SOLDER. FOR RECALIBRATING ADJUST SLUGS ONLY.

6-4. ALIGNMENT PROCEDURE

	Signal Generator Connections	Signal Generator Frequency	Band Selector Setting	Output Connections	Selectivity Setting	Remarks
50. 75 KC IF ALIGNMENT						
1	High side directly to alignment point "A" (terminal 1 of T2). See Figure 11. Low side to chassis.	50. 75 KC (unmod.)	80M	VTVMDC probe to alignment point "B" (junction of R30, R31, and C30). See Figure 11. -----	. 5 KC	Remove 1st conv. oscillator tube V6 from its socket to prevent signal interference. Adjust top slug of T102, T103, T3 and T4 (50. 75 KC IF's) for maximum indication, maintaining approx. 1 volt reading on VTVM.
ALIGNMENT OF 1600 KC 2nd CONV. OSC. & 1650 KC IF's						
2	High side directly to alignment point "C" (pin 7 of V2). Low side to chassis.	1650 KC (mod)	80M	Output meter across appropriate speaker terminals. (VTVM to alignment point "B" if it is desired to monitor detector voltage.)	5 KC	Replace V6 removed in step 1. Tune generator slowly thru 1650 KC to determine IF passband. Then set generator to center of passband, using sufficient generator output to obtain approx. 1/2 watt receiver output. If no output is obtained, the 1600 KC crystal oscillator may
<p>not be oscillating and it will be necessary to turn up the generator output and adjust the 1600 KC crystal activity adjustment (top slug of T201) until output is obtained. Adjust for maximum output by adjusting the signal generator frequency, crystal activity (top slug of T201) and the 1650 KC IF's (top and bottom slugs of T1 and T2). Note that the signal suddenly disappears when the crystal activity slug is turned into the coil and gradually drops in level when the slug is backed out of the coil. Set the crystal activity adjustment (top of slug of T201) for half output on the gentle slope side of maximum response. Then set the generator as near the center of the IF passband as possible and adjust the top and bottom slugs of T1 and T2 for maximum response. Tune through the passband and observe the shape of the response. If it is symmetrical, the adjustment is completed; if not, reset the generator frequency near the center of the passband and repeat T1 and T2.</p>						
ALIGNMENT OF 1700 KC 2nd CONV. OSC.						
3	High side directly to alignment point "C" (pin 7 of V2). Low side to chassis.	1650 KC (mod)	80M	Output meter across appropriate speaker terminals. (VTVM to alignment point "B" if it is desired to monitor detector voltage.)	5 KC	Set FUNCTION control at "UPPER" SIDEBAND. Tune generator slowly thru 1650 KC to determine IF passband. Then set generator to center of passband, using sufficient generator output to obtain approx. 1/2 watt receiver output. If no output is obtained,

ALIGNMENT OF 1700 KC 2nd CONV. OSC. (cont)

the 1700 KC crystal oscillator may not be oscillating and it will be necessary to turn up the generator output and adjust the 1700 KC crystal activity adjustment (bottom of slug of T201) until output is obtained. Adjust for maximum output by adjusting the signal generator frequency and the crystal activity (bottom of slug T201). Note that the signal suddenly disappears when the crystal activity slug is turned into the coil and gradually drops in level when the slug is backed out of the coil. Set the crystal activity adjustment (bottom slug of T201) for half output on the gentle slope side of maximum response.

IF SENSITIVITY CHECK

- 4 With the generator modulated 30% at 400 cycles and connected thru .05 mfd capacitor to the grid (pin 7) of the 1st mixer tube V2, the IF input required for 1/2 watt receiver output should be approximately 20 microvolts. This assumes the crystal activity is set for half of maximum response as outlined in steps 2 and 3 above.

RF ALIGNMENT

Before proceeding with the RF alignment, check the tuning dial for proper indexing. The dial should index with the low frequency end of the bands when the tuning gang is fully closed, and the CAL. RESET control (C86) should be set at its mid-position.

Use an amplitude modulated (30%) signal.

Set RF and AUDIO GAIN at "10". AVC and NOISE LIMITER at "OFF", SELECTIVITY at "2 KC", FUNCTION at "LOWER SIDEBAND".

Connect the output meter across the appropriate

speaker terminals. (Connect the VTVM to alignment point "B" if it is desired to monitor the detector voltage.) Maintain a 1/2 watt receiver output.

Connect generator between "A" terminal and ground of TS1. Connect high side of generator through 50 to 70 ohm carbon resistor to antenna terminal "A".

The oscillator frequency is higher than the signal frequency on all bands.

Step	Band Selector Setting	Generator & Receiver Frequency	Adjust for Maximum
5	80M (Band 1)	4.0 MC	C55 (osc trimmer) C40 (mixer trimmer) C2 (ant trimmer at midpoint)
	80M (Band 1)	3.5 MC	L18 (osc slug) L12 (mixer slug) L5 (ant slug)
6	40M (Band 2)	7.3 MC	C57 (osc trimmer) C39 (mixer trimmer) C2 (ant trimmer at midpoint)
	40M (Band 2)	7.0 MC	L17 (osc slug) L11 (mixer slug) L4 (ant slug)
7	20M (Band 3)	14.4 MC	C59 (osc trimmer) L10 (mixer slug) C2 (ant trimmer 1/3 open)
	20M (Band 3)	14.0 MC	L16 (osc slug) C37 (mixer pad) L3 (ant slug)
8	15M (Band 4)	21.5 MC	C63 (osc trimmer) L9 (mixer slug) C2 (ant trimmer 1/3 open)
	15M (Band 4)	21.0 MC	L15 (osc slug) C33 (mixer pad) L2 (ant slug)
9	10M (Band 5) (Cont. on page 16).	29.7 MC	C60 (osc trimmer) L8 (mixer slug) C2 (ant trimmer 1/3 open)

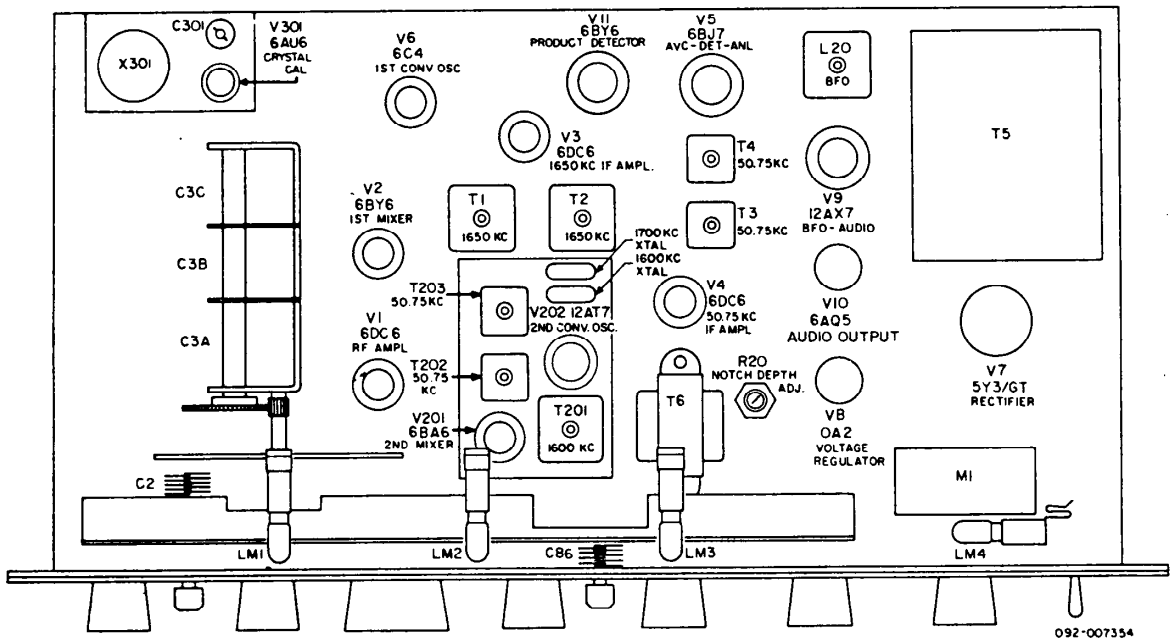

Figure 10. Top View Receiver Tube Locations And Alignment Points

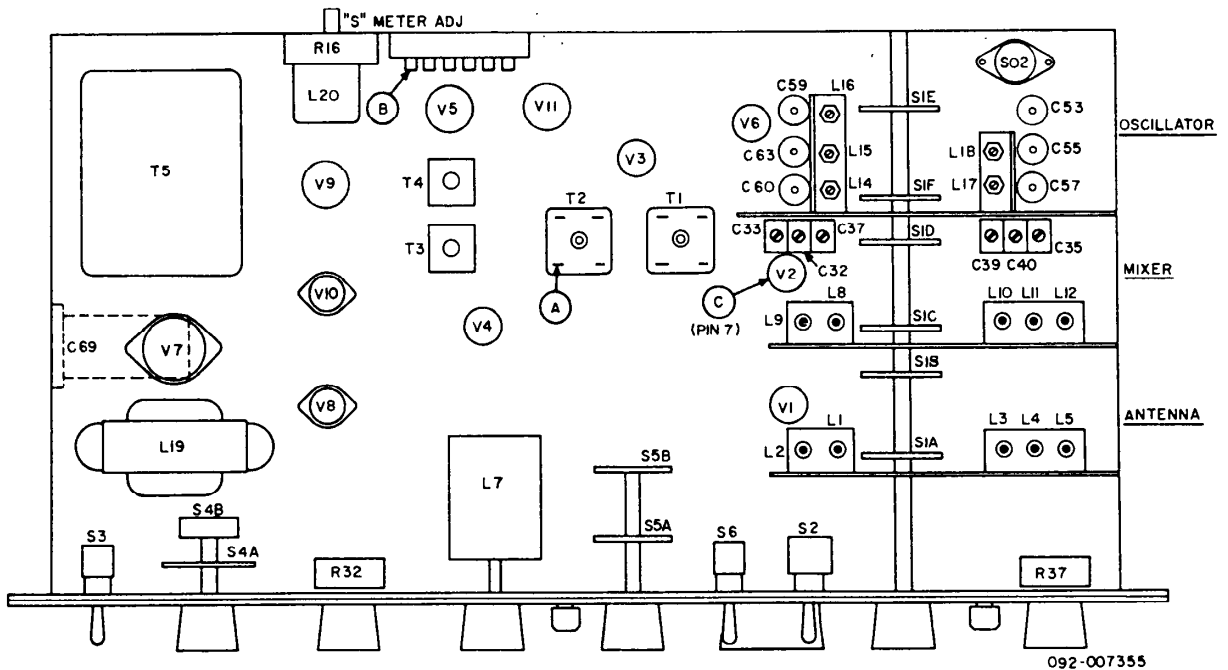

Figure 11. Bottom View Receiver Tube Locations And Alignment Points

Step	Band Selector Setting	Generator & Receiver Frequency	Adjust for Maximum
RF ALIGNMENT (cont)			
10	10M (Band 5)	28.0 MC	L14 (osc slug) C32 (mixer pad) L1 (ant slug)
	10 MC WWV (Band 6)	10.0 MC	C53 (osc trimmer) C35 (mixer trimmer)
BFO ADJUSTMENT Refer to Section 4-6.			
NOTCH FILTER ADJUSTMENT Refer to Section 4-7.			
"S" METER CALIBRATION Refer to Section 7-4.			
<p>Make both the mechanical and the electrical "S" meter zero adjustments.</p> <p>Connect the signal generator as for RF ALIGNMENT above. Use a 14.3 MC, 50 UV modulated signal.</p> <p>Set the receiver controls for AM reception on the</p>		<p>20M band and accurately tune in the signal.</p> <p>Set RF GAIN to "10" (maximum), AVC to "ON" and SELECTIVITY to "2 KC".</p> <p>Adjust core of T201 (Top, LSB; Bottom, USB) for S9 reading on "S" meter.</p>	

SECTION VII SERVICE DATA

7-1. 50.75KC IF SYSTEM

Figure 12 shows the type of coupling used in the 50.75 KC IF system. Note that inductive coupling is avoided by careful shielding of the IF coils and signal transfer occurs only through capacitance and resistance. By increasing the value of "C" and decreasing "R", the selectivity is made sharper while by decreasing "C" and increasing "R", the selectivity is made broader. The proper values of "C" and "R" are switched in the circuit by means of the SELECTIVITY control. "R" varies the "Q" of the tuned circuit and "C" varies the coupling. This R-C coupling arrangement affords a more accurate means of selectivity control than that readily obtainable by any other method.

7-2. CHASSIS REMOVAL

The chassis and front panel assembly can be easily withdrawn from the cabinet as a unit after removing four screws from the front panel, one at each side of the trim strip, and the two center screws above the dial scale; and the four screws on the underside of the cabinet.

7-3. TUBE AND DIAL LAMP REPLACEMENT

For complete access to the tubes and dial lamps,

remove the receiver from the cabinet (See paragraph 7-2). The tube and lamp locations are shown in Figure 10.

7-4 "S" METER ADJUSTMENTS

The mechanical adjustment of the "S" meter is accessible at the front of the meter. The mechanical adjustment has been accurately set at the factory and will normally not require any further adjustment. Adjustment can be made, if required, by turning off the receiver and carefully rotating the adjustment screw until the meter pointer is in line with the right-hand index mark. (Front panel must be removed - See steps 1 through 3 in paragraph 7-5.)

The electrical adjustment is made by carefully turning the "S" METER ADJ control R16 on the rear of the receiver chassis (Figure 11), until the pointer is in line with the left-hand index mark. The electrical adjustment should be made with the receiver on, RF GAIN at "0", BFO switch at "OFF", AVC switch at "ON", and FUNCTION switch at "LSB" or "USB". The settings of the remaining controls do not affect the "S" meter reading.

7-5. DIAL CABLE RESTRINGING

1. Remove the chassis from the cabinet (para. 7-2).

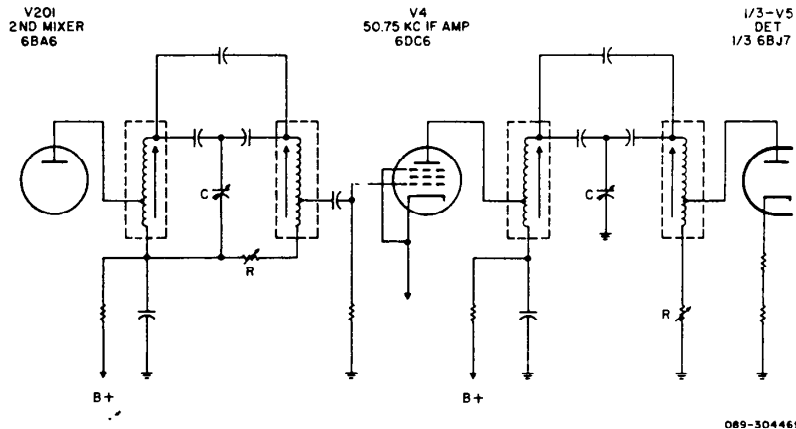

Figure 12. Equivalent Schematic Diagram of 50.75KC IF System

2. Remove the knobs and front panel. Remove the set screws holding the knobs in place with a bristol wrench. Remove the decorative nuts and spacers from the three toggle switches and "PHONES" jack. Remove the two remaining screws at the top of the front panel.
3. Remove the dial panel assembly by removing four screws, two at each side of the panel. Carefully remove the dial panel assembly, taking care not to damage the dial pointer.
4. Turn the tuning shaft fully counterclockwise so that the tuning gang capacitor is fully meshed.
5. Restring the dial cord as follows (Figure 13):
 - (a) Slide the dial cord through the hole in the tuning drum so the end with the crimped tab is on the front. See cutaway.
 - (b) Proceed clockwise (1) around the drum 3 1/2 turns and up over wheel "A" (2) to wheel "B" (3).
 - (c) Continue around wheel "B" (4) and across to wheel "C".
 - (d) Continue around wheel "C" (5) and back across to wheel "D" (6) and down to the tuning drum (7).
 - (e) Finish up by routing the cord into the drum slot and attach to the drum spring (8).
6. Set the pointer on the pointer rail and engage the dial cord. Do not crimp the tabs on the pointer at this time.
7. Temporarily set the dial panel assembly in place to line up the pointer. The tuning shaft should be completely counterclockwise and the tuning gang capacitor fully meshed.
8. Line up the pointer on the left-hand low frequency marks on the dial.
9. Remove the dial panel assembly and crimp the tabs on the pointer. Place a drop of cement on the pointer tabs and dial cord to permanently secure the pointer and dial cord.
10. Rotate the tuning shaft from the low end to the high end, and back to the low end. Do this several times. Check for backlash or jerky motion of the pointer. If this occurs, it may be necessary to shorten and tighten the dial cord, straighten the pointer, or both.
11. Replace the dial panel assembly, front panel, knobs, decorative nuts and washers, and return the chassis to the cabinet.

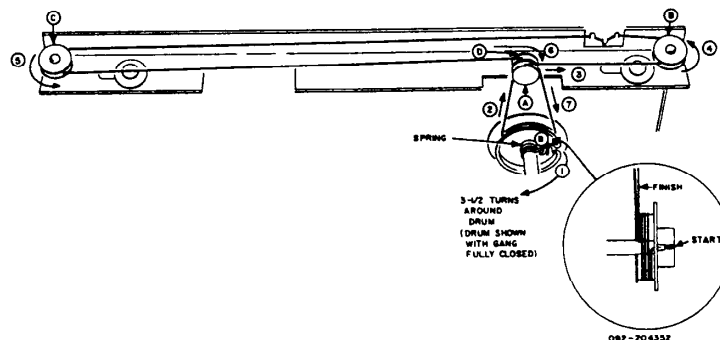

Figure 13. Dial Cord Stringing Diagram

SERVICE PARTS LIST

Schematic Symbol	Description	Hallcrafters Part Number	Schematic Symbol	Description	Hallcrafters Part Number
CAPACITORS			CAPACITORS (CON'T)		
C1,25,207	2.2 mmf., 500V., 10%; Neutralizer	047-200403-04	C77,82	.001 mfd., 600V., 20%; Molded Paper	499-034102
C2	4-50 mmf.; Ant. Trimmer	048-200450	C80	100 mmf., 10%, N750; Cer. Tub.	491-006101-95
C3A, B, C	Variable Capacitor, Main Tuning	048-300447	C85	8 mmf., NPO; Cer. Tub.	491-001080-22
C4	68 mmf., 5%, N150; Cer. Tub.	491-025680-53	C88	3-17 mmf., CAL. RESET	048-006468
C5	25 mmf., 10%, N750; Cer. Tub.	491-006250-95	C87	10 mmf., N750; Cer. Tub.	491-102100-94
C6,42,83	51 mmf., 10%, N330; Cer. Tub.	491-006510-73	C88,208,209,210,302,304	.01 mfd., 500V.; Cer. Disc	047-100224
C7,9,41,44,84,202,203,204,211	.02 mfd., 500V.; Cer. Disc	047-100242	C90	.25 mfd., 200V.; 20%; Molded Paper	499-014254
C8,10,11,12,14,15	.005 mfd., 450V.; Cer. Disc	047-100188	C91	.1 mfd., 200V., 20%; Molded Paper	499-024104
C13,19,26	.22 mfd., 200V., 20%; Molded Paper	499-014224	C92	.001 mfd., 500V., Cer. Disc	047-200320
C18	180 mmf., 5%, Mica	470-212181	C201	100 mmf., 10%; Cer. Tub.	491-026101-94
C17,18	7500 mmf., 500V., 5%; Silver Mica	470-422752	C301	8-50 mmf., N750; Trimmer	044-200437
C20,21	.047 mfd., 600V., 20%; Molded Paper	499-034473	C303	82 mmf., 500V., 10%; Mica	470-213820
C22	27 mmf.; Cer. Tub.	491-006270-94	*RESISTORS		
C23,24,205,206	390 mmf., 500V.; Silver Mica	470-232391	R1,5,35	22 ohm	451-252220
C27,28,29,89	220 mmf., 500V., 10%; Cer. Tub.	478-016221	R2,6,11,21,31	1 megohm	451-252105
C30	.047 mfd., 200V.; Molded Paper	499-014473	R3,39,42	180 ohm	451-252181
C31,78	.0033 mfd., 600V., 20%; Molded Paper	499-034332	R4	15K ohm, 1W	451-352153
C32,33,37	8-60, 3-35, 8-60 mmf.; Var. Triple Padder	044-200514	R7,48,203	22K ohm	451-252223
C34,49	5 mmf., ±.25 mmf., NPO; Cer. Tub.	491-001050-22	R8	330 ohm	451-252331
C35,39,40	3-35, 8-60, 8-60 mmf.; Var. Triple Trimmer	044-200515	R9,38	10K ohm, 1W	451-352103
C36	36 mmf., 2%, N220; Cer. Tub.	491-004360-63	R10,15	3.3K ohm, 1W	451-352332
C38	150 mmf., 2%, N470; Cer. Tub.	491-024151-83	R12	15 ohm	451-252150
C43	15 mmf., ±.25 mmf., NPO; Cer. Tub.	491-001150-22	R13,22	100 ohm	451-252101
C45	.0013 mfd., 500V., 5%; Mica	470-442132	R14,19	8.2K ohm	451-252822
C46,48	24 mmf., 500V., 2%; Duramic	482-151240	R16	500 ohm, variable; "S" Meter Adj.	025-200022
C47	85 mmf., 500V., 2%; Duramic	482-161850	R17	56 ohm	451-252560
C50	260 mmf., 500V., 2%; Duramic	482-161261	R18	100K ohm, 2W	451-652104
C51	56 mmf., 500V., 2%; Duramic	482-161560	R20	5K ohm, variable; NOTCH DEPTH Control	025-201716
C52	36 mmf., 2%, NPO; Cer. Tub.	491-004360-22	R23	39K ohm, 1W	451-352391
C53,55,57,59,60,63	3-30 mmf; Var. Trimmers	048-200415	R24	3.3K ohm	451-252332
C54	36 mmf., 2%, N330; Cer. Tub.	491-004360-73	R25,28,34,47,58	47K ohm	451-252473
C56	82 mmf., 2%, N150; Cer. Tub.	491-024820-52	R26,50,301,304	220K ohm	451-252224
C58	39 mmf., 2%, N330; Cer. Tub.	491-004390-73	R27,202	120K ohm	451-252124
C61	47 mmf., 2%, N330; Cer. Tub.	491-004470-73	R29	270K ohm	451-252274
C62	56 mmf., 2%, N220; Cer. Tub.	491-004560-62	R30	820K ohm	451-252824
C64	.01 mfd., 1400 W. V. D. C (AC Line By-Pass)	047-200752	R32	500K ohm, variable; AUDIO GAIN Control	025-201811
C65,67,71,79	.01 mfd., 600V., 10%; Molded Paper	499-031103	R33	3.9K ohm, 1W	451-352392
C68,70	.022 mfd., 600V., 10%; Molded Paper	499-031223	R37	10K ohm, variable; RF GAIN Control	025-201733
C68,72	4700 mmf., 600V., 10%; Molded Paper	499-031472	R38	330K ohm	451-252334
C69A,B,C,D	40-20-20 mfd., 350V.; 10 mfd., 50V.; Electrolytic	045-000697	R40,43	220 ohm	451-252221
C73	560 mmf., Mica (Part of L20)	470-232581	R41,44	390 ohm	451-252391
C74	10 mmf., N4700; Cer. Disc (Part of L20)	479-042100	R45	10K ohm	451-252103
C75	470 mmf., 500V., 10%; Mica (Part of L20)	470-213471	R46	2K ohm, 10W, wirewound	453-062202
C76	.022 mfd.; Molded Paper (Part of L20)	499-034223	R49	15 megohm	451-252156
			R51	470K ohm	451-252474
			R52	270 ohm, 1W	451-352271
			R53	27 ohm, 1W	451-352270
			R54,55,63,64	8.8 ohm	451-252068
			R56	2K ohm, 8W, wirewound	024-101258
			R57	1.2 megohm	451-252125
			R59,201	2.2K ohm	451-252222
			R60	150K ohm	451-252154
			R61	10 megohm	451-252124

SERVICE PARTS LIST (CONT.)

Schematic Symbol	Description	Halcrafter's Part Number	Schematic Symbol	Description	Halcrafter's Part Number
*RESISTORS (CON'T)			JACKS, PLUGS AND SOCKETS (CON'T)		
R62, 204, 205, 206, 207, 208, 303	100K ohm	451-252104		Socket, Octal	006-200296
R302	4.7K ohm	451-252472	SO1	Socket, Crystal	006-200873
*All resistors are 10%, 1/2 watt, carbon type unless otherwise specified.				Jack, Ant. Coax	036-100041
			SO2	Socket, 5 Pin	006-100186
				Plug, 5 Pin	035-100038
			SO3	Jack, Phone	036-100002
COILS			TUBES AND LAMPS		
L1	Coil, Antenna (10 Meter Band)	051-202573	V1, 3, 4	6DC6; RF Amplifier, 1650 KC IF	
L2	Coil, Antenna (15 Meter Band)	051-202574		Amplifier and 50.75 KC IF	
L3	Coil, Antenna (20 Meter & WWV 10 MC Bands)	051-202575	V2, 11	Amplifier	090-901328
L4	Coil, Antenna (40 Meter Band)	051-202576	V5	6BY6; Mixer & Product Detector	090-901114
L5	Coil, Antenna (80 Meter Band)	051-202577	V6	6BJ7; AVC, Detector & ANL Stage	090-901113
L6	Choke, RF; 540 UH	053-100107	V6	6C4; 1st Conv. Osc.	090-900830
L7	Coil, "T" Notch Assy.	051-102600	V7	5Y3/GT; Rectifier	090-901111
L8	Coil, Mixer (10 Meter Band)	051-202578	V8	OA2; Voltage Regulator	090-900001
L9	Coil, Mixer (15 Meter Band)	051-202579	V9	12AX7; BFO & Audio Stage	090-900038
L10	Coil, Mixer (20 Meter & WWV 10 MC Bands)	051-202580	V10	6AQ5A, Audio Output	090-901331
L11	Coil, Mixer (40 Meter Band)	051-202581	V201	6BA6; 2nd Mixer	090-901112
L12	Coil, Mixer (80 Meter Band)	051-202582	V202	12AT7; 2nd Conv. Osc.	090-900034
L13	Choke, RF	053-200475	V301	6AU6; Crystal Calibrator	090-900808
L14	Coil, Osc. (10 Meter Band)	051-202583	LM1, 2, 3	Pilot Lamp, #44 Bayonet	039-100003
L15	Coil, Osc. (15 Meter Band)	051-202572	LM4	Pilot Lamp, #44 Bayonet	039-100004
L16	Coil, Osc. (20 Meter Band)	051-202583	KNOB AND KNOB SKIRTS ASSEMBLY		
L17	Coil, Osc. (40 Meter Band)	051-202584		Knob, TUNING	015-301339
L18	Coil, Osc. (80 Meter Band)	051-202585		Knob, ANT. TRIMMER & CAL. RESET	015-200676
L19	Choke, Filter	056-300349		Knob, FUNCTION	015-101350
L20	Coil Assy., BFO (50 KC) (Inc. C73, C74, C75, C76)	054-200054		Knob, SELECTIVITY	015-101348
L201, 202	Choke, RF	053-400008		Knob, BAND SELECTOR	015-101347
TRANSFORMERS				Knob, NOTCH FREQUENCY	015-001548
				Knob, RF & AUDIO GAIN	015-101346
T1, 2	Transformer, IF (1650 KC)	050-200488	MISCELLANEOUS PARTS		
T3, 4, 202, 203	Transformer, IF (50.75 KC)	050-200489		Bracket, Main Tuning Shaft	067-207001
T5	Transformer, Power	052-400681		Cabinet	066-502384
T6	Transformer, Audio Output	055-300407		Cable, Coaxial	087-006321
T201	Transformer, 2nd Conv. Osc. (1600-1700 KC)	050-300689	X201, 202	Cord, Dial	038-100042
SWITCHES				Crystal Pair, Matched; 1600 KC and 1700 KC Crystals	019-101902
S1A	Wafer, Antenna Input	062-200150		Crystal Marker Assem. (100 KC)	001-902508
S1B	Wafer, RF Amp. Grid	062-200151	X301	Crystal Marker (100 KC)	019-202351
S1C	Wafer, RF Amp. Plate	062-200152	CR301	Crystal Diode, Type 1N295	019-201980
S1D	Wafer, Mixer Grid	062-200153		Dial Light Assem.	086-300467
S1E	Wafer, Osc. Cathode	062-200154		Dial Scale, Glass	083-400689
S1F	Wafer, Osc. Grid	062-200155	F1	Flywheel	071-100178
S2A, B	Switch, DPST; AVC ON-OFF	060-100285		Foot, Mtg.	016-100007
S3	Switch, SPST; ANL	060-100139		Fuse W/Leads	039-100338
S4	Switch, FUNCTION	060-202070		Lock, Line Cord (Male)	076-100397-01
S5	Switch, SELECTIVITY	060-202071		Lock, Line Cord (Female)	076-100397-02
S6	Switch, DPDT; BFO	060-200575		Panel, Front	068-400868
JACKS, PLUGS AND SOCKETS				Plate, Dial	063-303972
PL1	Line Cord and Plug	087-201669-02	M1	Pointer	082-200409
	Socket, Tube; 7 Pin Min.	006-100644		"S" Meter	082-300431
	Socket, Tube; 7 Pin Min.	006-100645		Retainer, Glass	076-100663
	Socket, Tube; Octal	006-200296		Shaft & Index Plate, Band Switch	074-202152
	Socket, Tube; 9 Pin Noval	006-200500		Shaft, Pinion	074-202119
	Socket, Tube; 7 Pin Min.	006-200505		Shaft, Tuning	074-202091
	Socket, Tube; 7 Pin Min.	006-200759	TS1	Spring, Torsion	075-200697
	Socket, Tube; 7 Pin Min.	006-100347	TS2	Terminal Board, Antenna	088-202026
			TS3	Terminal Board, Mute Strip	088-202025
				Terminal Board, Speaker	088-100578
				Trim Strip, Large	007-400747
				Trim Strip, Small	007-200746

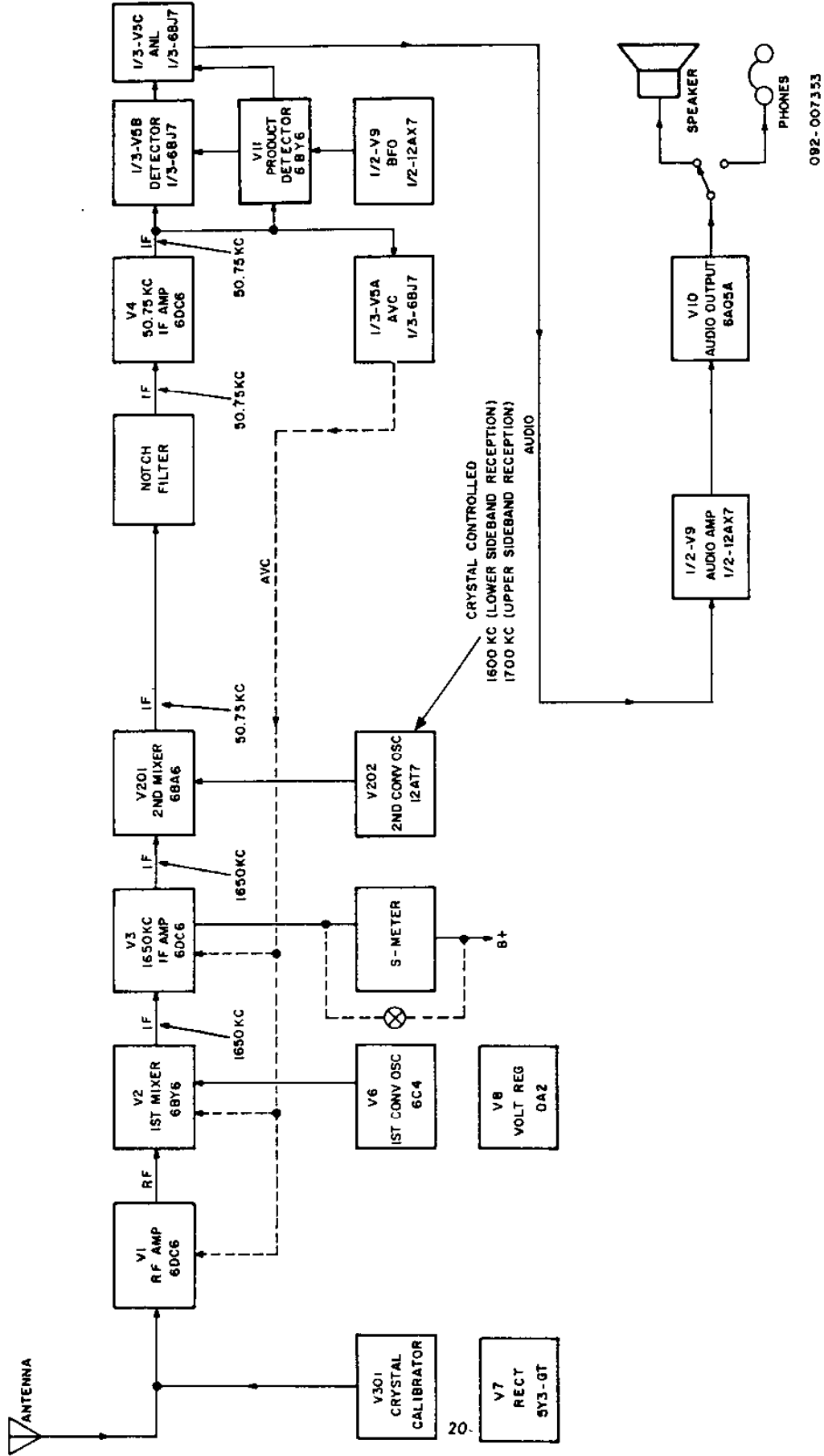
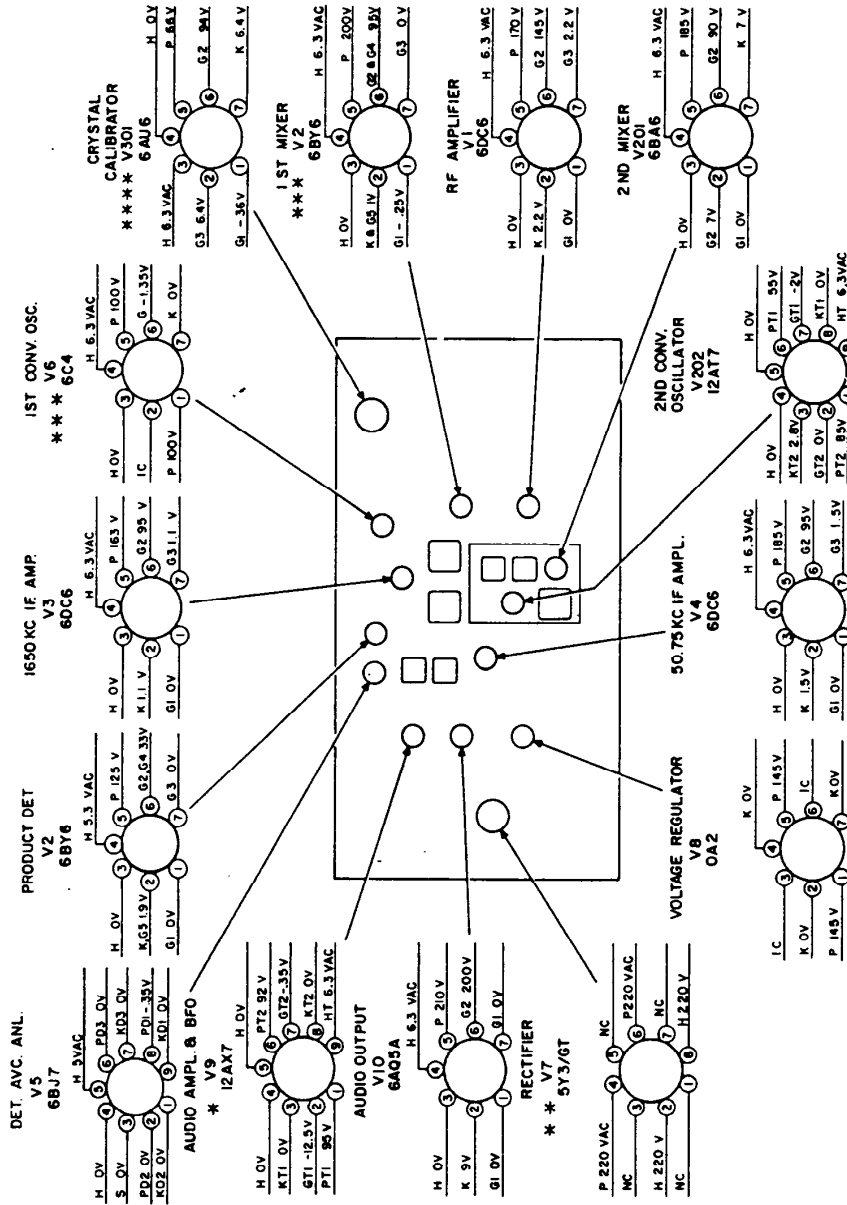

Figure 14. Block Diagram of SX-111 Receiver

092-007353



092-007356

Figure 15. Voltage Chart

- NOTES**
VOLTAGE READINGS TAKEN UNDER THE FOLLOWING CONDITIONS:
1. LINE VOLTAGE - 117 VOLTS, 60 CYCLES AC
2. ANTENNA TERMINALS SHORTED, RF GAIN AT "10", BFO SWITCH AT "OFF", AVC AT "ON", NOISE LIMITER AT "OFF", FUNCTION AT "LOWER SIDE-BAND", SELECTIVITY AT "5MC.", AND BAND SELECTOR AT "60M."
3. ALL VOLTAGES ARE DC AND POSITIVE UNLESS OTHERWISE SPECIFIED. DC AND AC VOLTAGES MEASURED WITH 20,000 OHMS-PER-VOLT METER.
4. ALL VOLTAGES MEASURED BETWEEN TUBE SOCKET TERMINALS AND CHASSIS UNLESS OTHERWISE SPECIFIED.
5. VOLTAGES SHOWN FOR V202 ARE WITH FUNCTION CONTROL AT "LOWER SIDE-BAND" IN THE "UPPER SIDE-BAND" POSITION. THE VOLTAGES OF THE TWO TRIODE SECTIONS ARE REVERSED THE GRID VOLTAGE WILL VARY WITH CRYSTAL ACTIVITY.
* VOLTAGES FOR PINS 1 & 2 OF V9 ARE TAKEN WITH BFO SWITCH AT "ON."
** 5 VAC MEASURED ACROSS PINS 2 & 8
*** VOLTAGE VARIES WITH SETTING OF TUNING GANG AND BANDSWITCH.
NM - NOT MEASURABLE
IC - INTERNAL CONNECTION
NC - NO CONNECTION
HT - HEATER MID-TAP
IS - INTERNAL SHIELD IM
*** MEASURED IN CALIBRATE POSITION.

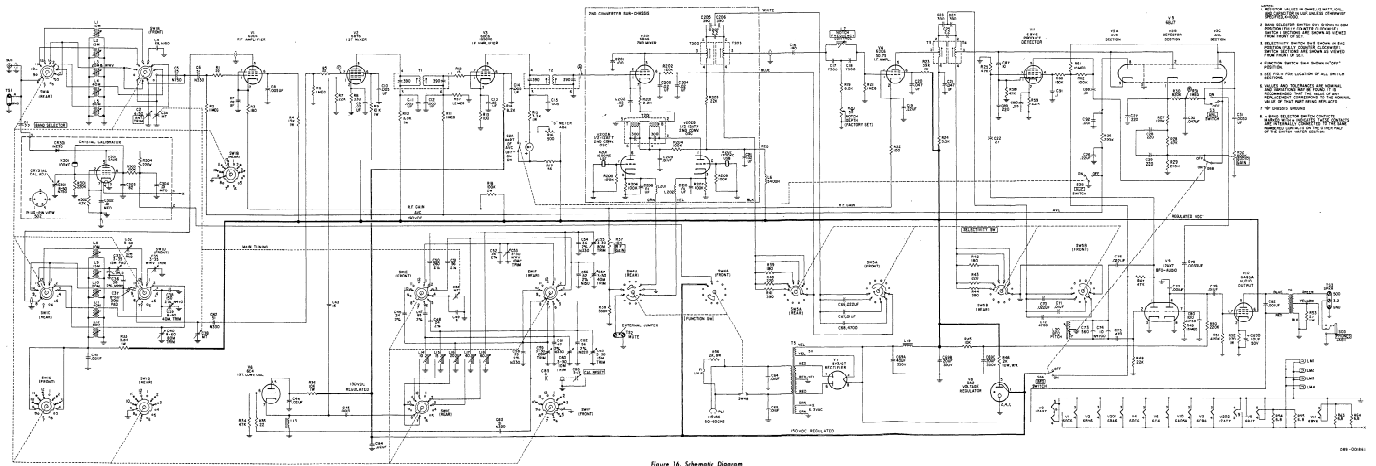

Figure 14. Schematic Diagram